



No-sweat hauling of heavy, bulky items is yours when you hitch this wagon to your yard tractor

Handy trailer for yard tracs

By HANK ADAMS

A little wagon building
gives you big load-hauling
capacity to save time
and your back
in yard work

• IF YOU'VE INVESTED in one of those popular garden tractors or riding mowers, this handy cart will give you extra benefits.

It would cost about three times as much to get similar features in a commercial cart, and you can cut building costs in half if you can swipe a wheel or two from obsolete wheelbarrows.

Built to the dimensions shown on the opposite page, the cart has a heaped capacity of about 7-1/2 cu. ft., or roughly 1000 lbs. of dirt or stone. With the stake sides in place, it will haul a huge pile of leaves, grass clippings or trash. It takes 5-1/2-7hp to haul half-ton loads, so if your power unit has less, you'll either have to make a smaller trailer or be careful how you load this one.

The body is 3/4-in. exterior plywood, assembled

It beats a wheelbarrow! For this job, the tailgate comes off and lets you dump loads from the seat



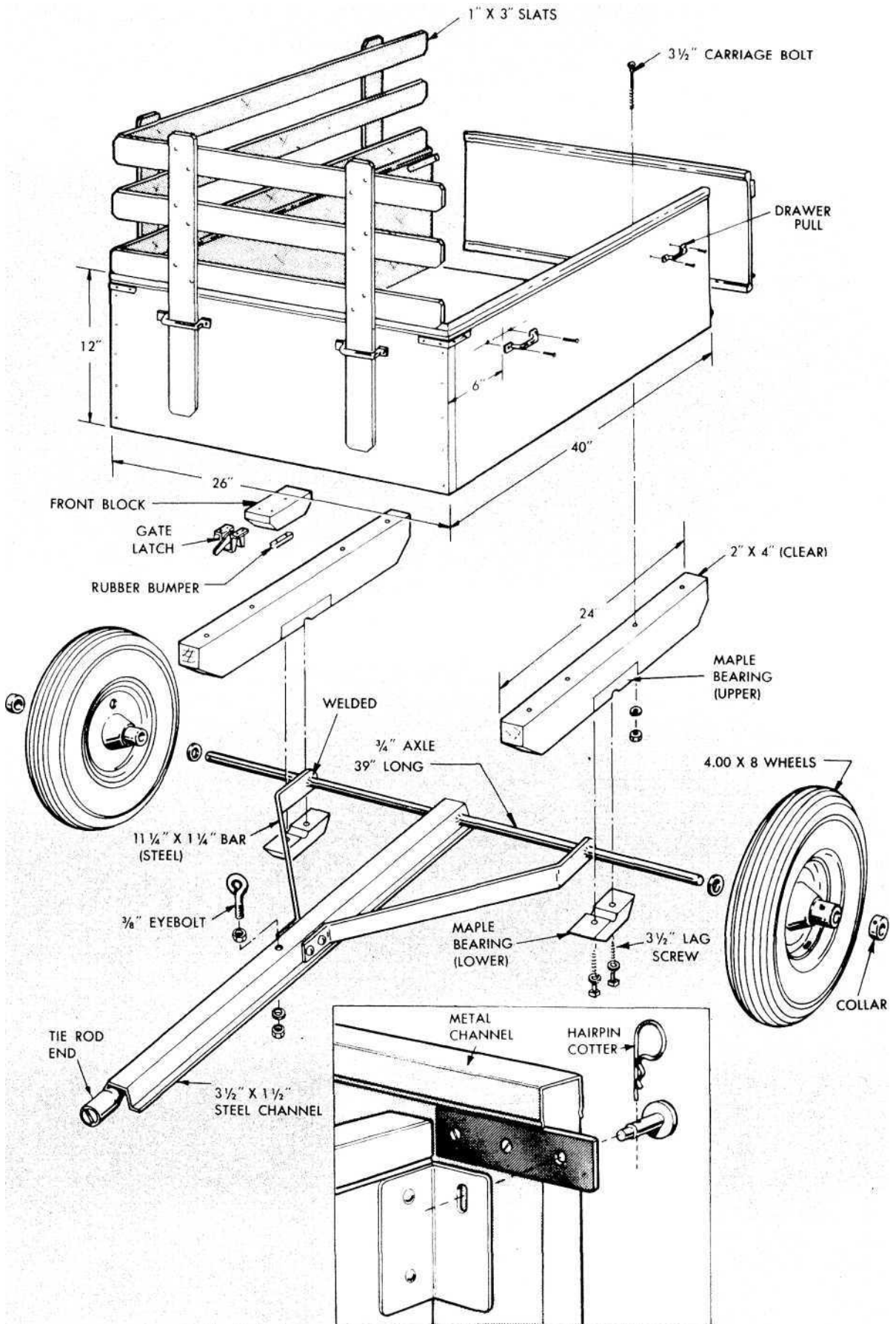

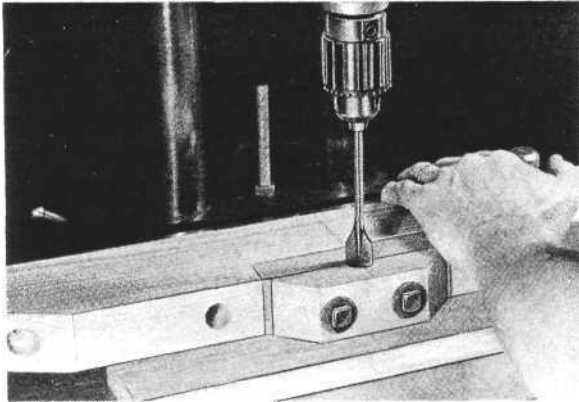

Drill the axle hole after gluing the upper bearing block into the beam and fastening the lower bearing to it with lagbolts. Use joint line to center bit

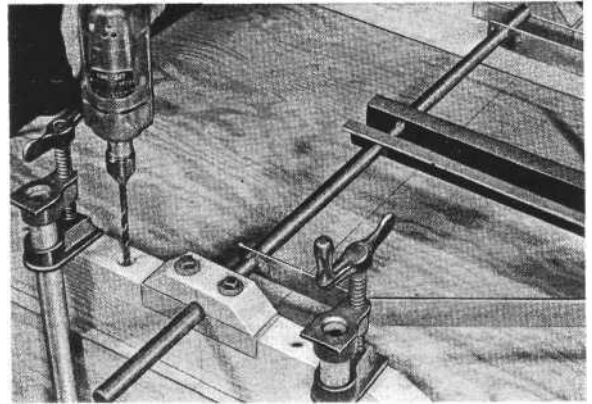

To assure a square assembly, weld the axle to the drawbar unit and fasten it to beams before you drill 1/4-in. holes into the trailer bed for carriage bolts

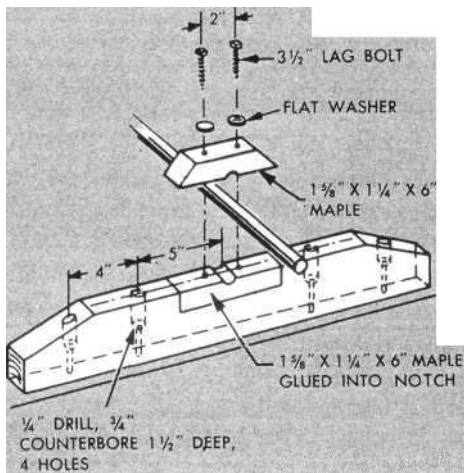

with screw-type nails and waterproof glue. The top edges are capped for durability—the metal raceway used for certain wiring will fit over 3/4-in. panels.

Centering the body over the axle makes dumping easier, but a balanced load tends to lift against the hitch. It's best to locate the axle 2 or 3 in. behind the center; this also increases the dump angle. Before mounting the axle, apply stick graphite to the bearing surfaces.

A steering tie rod and ball joint from an old car provide a universal hitch. In the model shown, the tip of the tie rod is welded inside a drawbar made of hat-section channel. This could also be U-channel, or even 1-1/2 in. pipe.

No accidental dumps when you install a gate latch under the trailer bed to engage an eyebolt in the drawbar. Bumper block, behind latch, keeps bed level

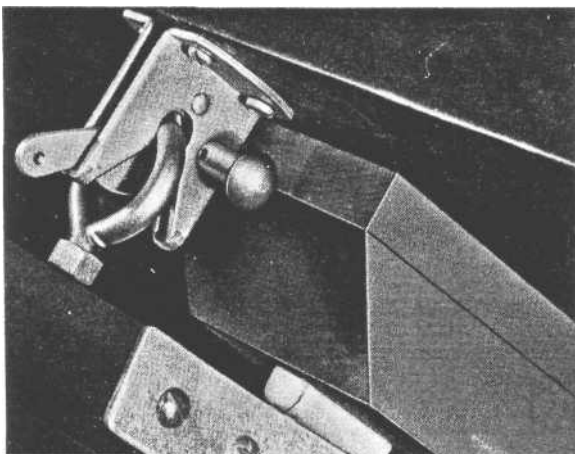

Mount the slide bolts horizontally at lower corners of the tailgate. When the gate is pivoted up and back, extended bolts on sides' top edges hold gate

